

# SLOT

CONNECTOR PITCH 2.54mm FOR PCB DIP SOLDER  
DIP SOLDER TYPE

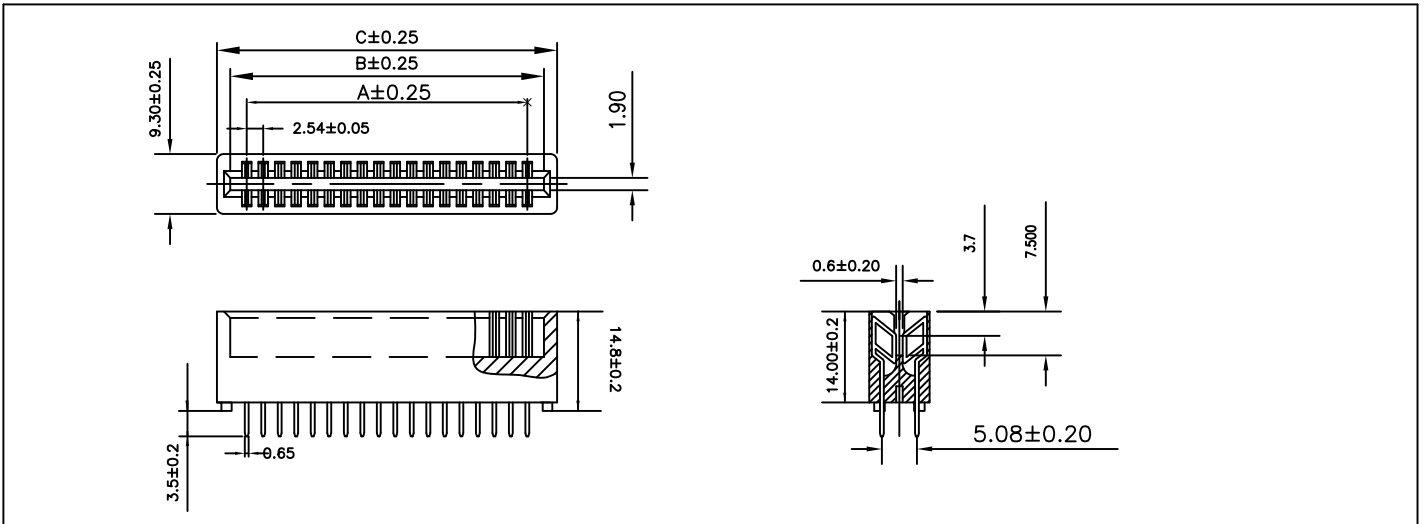

## ■ PART NO.

SA XX D  
① ② ③

- ① Series no.
- ② No. of circuits
- ③ Tail Style or Tail Length
- D: Straight Tail
- R: Right Angle
- Y: Straddle Tail

## ■ MATERIAL

- Insulator: Glass-Fiber P.B.T(UL94V-0)
- Contact: Phosphor Bronze (P) or Brass (B)
- Plating: Gold Plating Over Nickel.

## ■ SPECIFICATIONS

- Insulation Resistance: 5000 MΩ min at 500 VDC
- Dielectric Withstanding Voltage: 1000 V-AC/1 min
- Current Rating: 3A
- Contact Resistance: 20mΩ max
- Operating Temperature: -55°C to 105°C
- Insertion Force: 340g max per pair
- Withdrawal Force: 28g min per pair

## ■ DIMENSIONS

Circuits	A	B	C	Circuits	A	B	C
6	5.08	10.66	14.22	48	58.42	64.00	67.56
8	7.62	13.20	16.76	50	60.96	66.54	70.10
10	10.16	15.74	19.30	52	63.50	69.08	72.64
12	12.70	18.28	21.84	54	66.04	71.62	75.18
14	15.24	20.82	24.38	56	68.58	74.16	77.72
16	17.78	23.36	26.92	58	71.12	76.70	80.26
18	20.32	25.90	29.46	60	73.66	79.24	82.80
20	22.86	28.44	32.00	62	76.20	81.78	85.34
22	25.40	30.98	34.54	64	78.74	84.32	87.88
24	27.94	33.52	37.08	66	81.28	86.86	90.42
26	30.48	36.06	39.62	68	83.82	89.40	92.96
28	33.02	38.60	42.16	70	86.36	91.94	95.50
30	35.56	41.14	44.70	72	88.90	94.48	98.04
32	38.10	43.68	47.24				
34	40.64	46.22	49.78				
36	43.18	48.76	52.32				
38	45.72	51.30	54.86				
40	48.26	53.84	57.40				
42	50.80	56.38	59.94				
44	53.34	58.92	62.48				
46	55.88	61.46	65.02				